

SELLERS

SPECIFICATION SHEET NO.

9001

APRIL 1, 2007

HEAT-N-STORE STORAGE TYPE WATER HEATER HEATING MEDIUM – BOILER WATER

GENERAL DESCRIPTION

The Sellers Heat-N-Store is an automatic, completely packaged storage type large volume water heater. The water is heated with a heat exchanger using boiler water as the heating medium. The heater has two sections incorporated into one assembly – a recovery section and a storage section.

RECOVERY SECTION

The recovery section consists of a shell and tube type heat exchanger into which boiler water is admitted at a controlled rate by a flow control valve. The water being heated is continuously pumped at a fixed rate through the shell of the heat exchanger. By a series of baffles, turbulent scrubbing of the tube surfaces more than doubles the rate of heat transfer.

STORAGE SECTION

The storage section is an ASME Code Section VIII built cylindrical tank with convex heads. It is provided with a 12" x 16" manhole. Epoxy Phenolic lining and insulated with 2" steel jacketed fiberglass are standard. Storage section capacities and dimensions of all models are found on the inside pages.

The completed Heat-N-Store is factory tested and mounted on a skid type base. The package of controls and accessories listed in this specification sheet is factory piped and installed. All controls are tested after installation to insure proper functioning. The heater arrives ready for installation and operation.

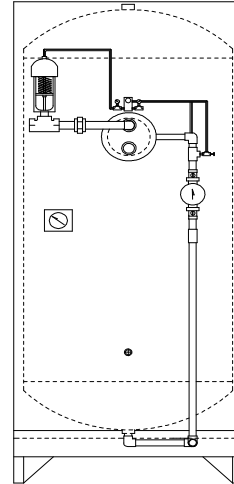

Sellers Vertical Water-to-Water
Heat-N-Store Water Heater

SELECTING THE MODEL NUMBER

The Heat-N-Store makes the specifying, purchase and installation of a storage water heating system a simple procedure.

To select a model, determine by any preferred sizing method the hourly recovery rate and the storage volume which best meet the job requirements. Among factors affecting the ratio between the capacities of the two sections of the Heat-N-Store are the rate and duration of peak periods of hot water use and the length of recovery periods.

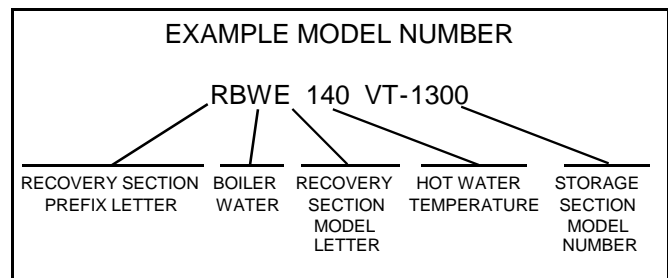

SELLERS ENGINEERING CO., MANUFACTURING BOILERS AND WATER HEATERS SINCE 1931.



WATER HEATER RECOVERY CAPACITIES

RECOVERY MODEL LETTER	A	B	C	D	F	G	H	I	J	K
40 TO 140 DEGREES F. (GALLONS PER HOUR)										
RECOVERY CAPACITY - 40-140 DEGREES	180	300	390	660	900	1,740	2,400	3,180	3,840	4,920
REQUIRED 180 DEGREE BOILER WATER	2,400	3,300	9,600	9,600	7,200	22,200	22,200	22,200	22,200	28,500
40 TO 140 DEGREES F. (GALLONS PER HOUR)										
RECOVERY CAPACITY - 40-120 DEGREES	390	600	840	1,440	2,460	3,840	5,640	6,000	6,900	4,920
REQUIRED 180 DEGREE BOILER WATER	5,100	5,100	9,600	9,600	15,300	22,200	22,200	22,200	22,200	28,500

* 25 ΔT *25 ΔT *30 ΔT

*NOTES: RECOVERY CAPACITIES APPLY TO SINGLE WALL UNITS ONLY.
CONSULT FACTORY FOR DOUBLE WALL CAPACITIES.
BASED ON A 20 DEGREE BOILER WATER TEMPERATURE DROP UNLESS NOTED.

STANDARD EQUIPMENT FURNISHED

Pressure Vessel: ASME stamped.
Manhole: 12" x 16"
Handholes: 3-1/2" x 4-1/2"
Base: Heavy duty structural steel skid
Insulation: 2" fiberglass with double painted steel jacket
Epoxy Lining: Epoxy phenolic lining applied to sand blasted surface and baked at high temperature
Heat Exchanger with copper tubes. Consult the factory for optional tubing material
Boiler water flow control valve
Heat exchanger circulating pump
Pump isolation valves
Pump loading valve

Thermal Sensor
Lifting lug(s)
Pressure Gauge: 4-1/2" dial type mounted on pigtail
Temperature Gauge: 5" dial type
Boiler water inlet and outlet temperature gauges
Temperature and Pressure Relief Valve
Magnesium Anodes: Two (2) 1-5/16" x82 or longer
Copper water line piping
Cold water distribution baffle
Ten year warranty on pressure vessel
Finished with heavy jade green machinery enamel
Initial start-up and operator's instruction provided
by a company representative

VERTICAL HEAT-N-STORE PACKAGED WATER HEATER

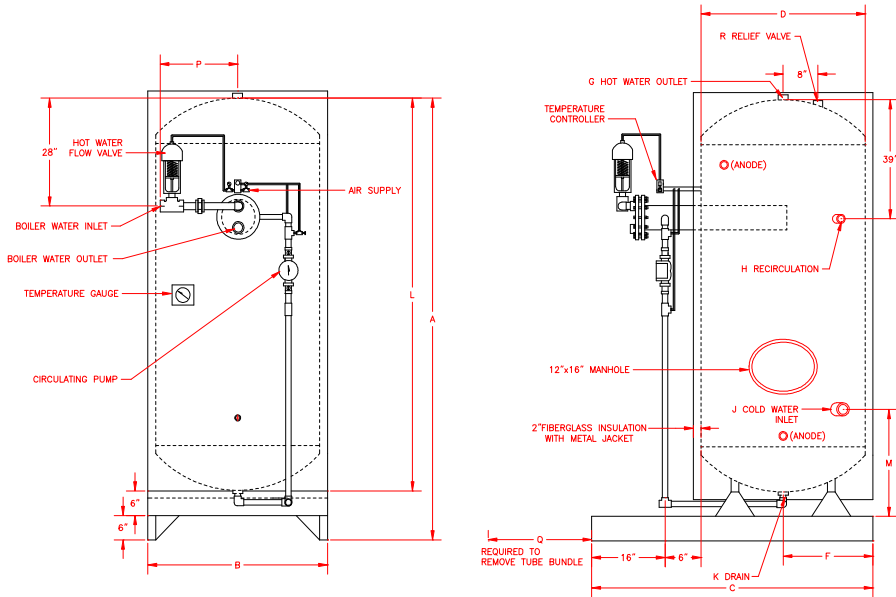

DIMENSIONS

CAPACITY (GALLONS)	MODEL NUMBER	D	L	A	B	C	F	G	H	J	K
170	VT-170	30	60	72	34	54	17	1 1/2	1	1 1/2	1 1/2
200	VT-200	30	72	84	34	54	17	1 1/2	1	1 1/2	1 1/2
240	VT-240	30	84	96	34	54	17	1 1/2	1	1 1/2	1 1/2
280	VT-280	36	72	84	40	60	20	1 1/2	1	1 1/2	1 1/2
335	VT-335	36	84	96	40	60	20	2	1	2	1 1/2
390	VT-390	36	96	108	40	60	20	2	1	2	1 1/2
460	VT-460	42	84	96	46	66	23	2	1 1/2	2	1 1/2
530	VT-530	42	96	108	46	66	23	2 1/2	1 1/2	2 1/2	1 1/2
600	VT-600	42	108	120	46	66	23	2 1/2	1 1/2	2 1/2	1 1/2
680	VT-680	48	96	108	52	72	26	2 1/2	1 1/2	2 1/2	1 1/2
770	VT-770	8	108	120	52	72	26	3	1 1/2	3	1 1/2
865	VT-865	48	120	132	52	72	26	3	1 1/2	3	1 1/2
1300	VT-1300	60	120	132	64	84	32	3	1 1/2	3	2
1980	VT-1980	72	120	132	72	96	38	3	1 1/2	3	2

*** All Dimensions In Inches ***

RECOVERY SECTION DIMENSIONS

RECOVERY MODEL LETTER		A	B	C	D	E	F	G	H	I	J	K
MINIMUM TANK DIAMETER*		30	42	30	42	30	42	42	60	72	84	84
WATER VALVE LOCATION	P	22	28	27	27	33	33	41	45	45	45	55
EXCHANGER REMOVAL	Q	32	44	34	46	35	47	51	63	75	87	87
RELIEF VALVE-IPS	R	1.5	1.5	1.5	1.5	1.5	1.5	2	2	2-2	2-2	2-2

*NOTE: Small diameter vertical tanks may be used if abnormal overhang is acceptable.

HORIZONTAL HEAT-N-STORE PACKAGED WATER HEATER

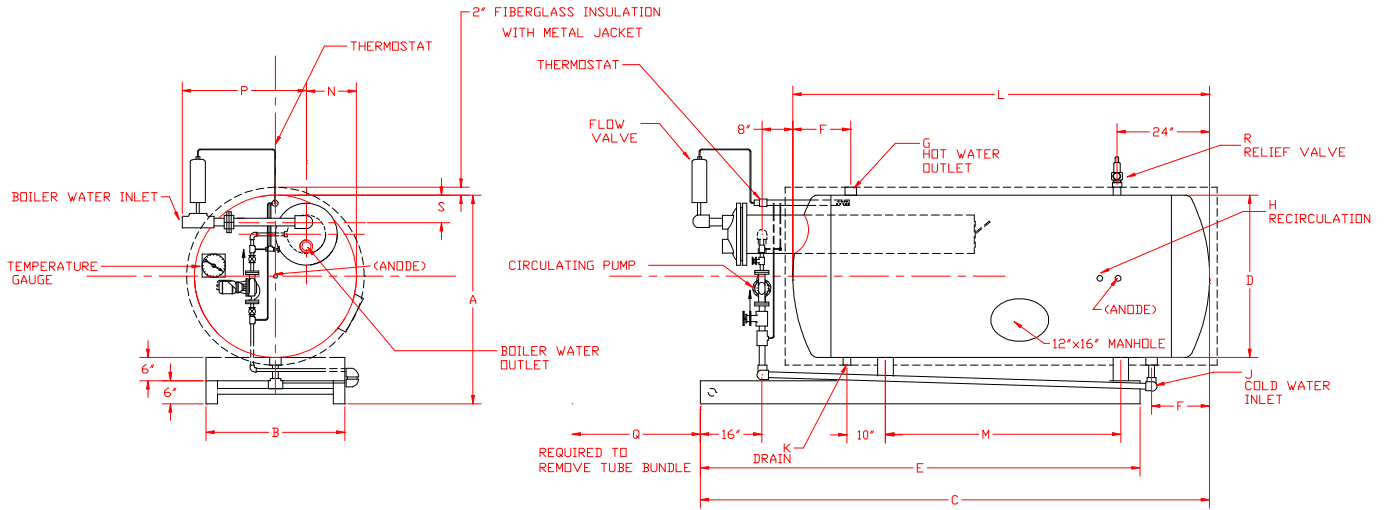

DIMENSIONS

CAPACITY (GALLONS)	MODEL NUMBER	D	L	A	B	C	E	F	G	H	J	K	M	N	S
170	HT-170	30	60	42	24	84	70	12	1 1/2	1	1 1/2	1 1/2	20	11	8
200	HT-200	30	72	42	24	96	82	12	1 1/2	1	1 1/2	1 1/2	32	11	8
240	HT-240	30	84	42	24	108	94	12	1 1/2	1	1 1/2	1 1/2	44	11	8
280	HT-280	36	72	48	30	96	81	13	1 1/2	1	1 1/2	1 1/2	30	12	9
335	HT-335	36	84	48	30	108	93	13	2	1	2	1 1/2	42	12	9
390	HT-390	36	96	48	30	120	105	13	2	1	2	1 1/2	54	12	9
460	HT-460	42	84	54	36	108	90	15	2	1 1/2	2	1 1/2	37	13	10
530	HT-530	42	96	54	36	120	102	15	2 1/2	1 1/2	2 1/2	1 1/2	49	13	10
600	HT-600	42	108	54	36	132	114	15	2 1/2	1 1/2	2 1/2	1 1/2	61	13	10
680	HT-680	48	96	60	42	120	100	17	2 1/2	1 1/2	2 1/2	1 1/2	45	14	11
770	HT-770	48	108	60	42	132	112	17	2 1/2	1 1/2	2 1/2	1 1/2	57	14	11
865	HT-865	48	120	60	42	144	124	17	3	1 1/2	3	1 1/2	69	14	11
1050	HT-1050	48	144	60	42	168	148	17	3	1 1/2	3	1 1/2	93	14	11
1235	HT-1235	48	168	60	42	192	172	17	3	1 1/2	3	1 1/2	117	14	11
1000	HT-1000	60	96	72	54	120	96	19	3	1 1/2	3	2	39	16	12
1300	HT-1300	60	120	72	54	144	120	19	3	1 1/2	3	2	63	16	12
1600	HT-1600	60	144	72	54	168	144	19	3	1 1/2	3	2	87	16	12
1900	HT-1900	60	168	72	54	192	168	19	3	1 1/2	3	2	111	16	12
1980	HT-1980	72	120	84	66	144	115	23	3	1 1/2	3	2	54	18	14
2400	HT-2400	72	144	84	66	168	139	23	3	1 1/2	3	2	78	18	14
2700	HT-2700	72	168	84	66	192	163	23	3	1 1/2	3	2	102	18	14
3050	HT-3050	84	144	96	78	168	139	23	3	1 1/2	3	2	78	20	16
4000	HT-4000	96	144	108	90	168	138	24	3	1 1/2	3	2	76	21	18

*** All Dimensions In Inches ***



P.O. Box 48 · Danville, Kentucky 40423-0048

Phone: 859/236-3181

Web-site: sellersengineering.com